

# PT-40G-SR-BD-RX

## DATASHEET



### GENERAL DESCRIPTION

PT-40G-SR-BD-RX is a two-channel, LC Duplex, Fiber Optic QSFP+ transceiver for 40 Gigabit Ethernet applications. This transceiver is a high performance module for short-range duplex data communication. It integrates four electrical data lanes in each direction into transmission over a single LC duplex fiber optic cable. Each electrical lane operates at 10.3125 Gbps and conforms to the 40GE XLPI interface.

The transceiver internally multiplexes an XLPI 4x10G interface into two 20Gb/s electrical channels, receiving each optically over one simplex LC fiber using bi-directional optics. This results in an aggregate bandwidth of 40 Gbps into a duplex LC cable. This allows reuse of the installed LC duplex cabling infrastructure for 40 GbE application. Link distances up to 100 m using OM3 and 150 m using OM4 optical fiber are supported. These modules are designed to operate over multi-mode fiber systems using a nominal wavelength of 850 nm on one end and 900 nm on the other end. The electrical interface uses a 38 contact QSFP+ type edge connector. The optical interface uses a conventional LC duplex connector.

### PRODUCT FEATURES

- ▶ Compliant with the 40 GbE XLPI electrical specification per IEEE 802.3ba-2010
- ▶ Compliant with QSFP+ SFF-8436 Specification
- ▶ Aggregate bandwidth of 40 Gbps
- ▶ Duplex LC connector receive only
- ▶ Operates at 10.3125 Gbps per electrical channel with 64b/66b encoded data
- ▶ QSFP MSA compliant
- ▶ Integrated ROSA for up to 100 m reach over OM3 Multi-Mode Fiber (MMF) and reach over 150 m over OM4 MMF
- ▶ Single +3.3V power supply operating without digital diagnostic functions
- ▶ Temperature range 0°C to 70°C
- ▶ RoHS compliant
- ▶ Utilizes a standard LC duplex fiber cable allowing reuse of existing cable infrastructure

### APPLICATIONS

- ▶ 40 Gigabit Ethernet interconnects
- ▶ Datacom/Telecom switch & router connections
- ▶ Data aggregation and backplane applications
- ▶ Proprietary protocol and density applications

## ABSOLUTE MAXIMUM RATINGS

It has to be noted that the operation in excess of any individual absolute maximum ratings might cause permanent damage to this module.

Parameter	Symbol	Min	Max	Unit
Storage Temperature	$T_s$	-40	+85	°C
Power Supply Voltage	$V_{cc,T,R}$	-0.5	4	V
Relative Humidity (non-condensing)	RH	0	85	%

## RECOMMENDED OPERATING ENVIRONMENT

Parameter	Symbol	Min	Typical	Max	Unit	Note
Case Operating Temperature	$T_c$	0		+60	°C	
Supply Voltage	$V_{cc,T,R}$	+3.13	3.3	+3.47	V	
Supply Current	$I_{cc}$			1000	mA	
Power Dissipation	PD			3.5	W	

## OPTICAL PARAMETERS

TOP = 0 TO 70 °C, VCC = 3.0 TO 3.6 VOLTS

Parameter	Symbol	Min	Typical	Max	Unit	Note
<b>Receiver</b>						
Optical Center Wavelength CH1	$\lambda$	882	910	918	nm	
Optical Center Wavelength CH2	$\lambda$	832	850	868	nm	
Receiver Sensitivity per Channel	$R_{en}$	+3	-6	-6.5	dBm	
Maximum Input Power	$P_{MAX}$	+5			dBm	
Damage Threshold	$P_{Min}$	+7				
Receiver Reflectance	$R_{rx}$			-12	dB	
LOS De-Assert	LOSD			-14	dBm	
LOS Assert	LOSA	-30			dBm	
LOS Hysteresis	LOSH	0.5			dB	

## ELECTRICAL CHARACTERISTICS

TOP = 0 TO 70 °C, VCC = 3.13 TO 3.47 VOLTS

Parameter	Symbol	Min	Typical	Max	Unit	Note
Data Rate per Channel			10.3125	11.2	Gbps	
Power Consumption			2.5	3.5	W	
Supply Current	Icc		0.75	1.0	A	
Control I/O Voltage-High	VIH	2.0		Vcc	V	
Control I/O Voltage-Low	VIL	0		0.7	V	
Inter-Channel Skew	TSK			150	Ps	
RESETL Duration			10		Us	
RESETL De-assert time				100	ms	
Power On Time				100	ms	
<b>Transmitter</b>						
Single Ended Output Voltage Tolerance		0.3		4	V	1
Common mode Voltage Tolerance		15			mV	
Transmit Input Diff Voltage	VI	120		1200	mV	
Transmit Input Diff Impedance	ZIN	80	100	120		
Data Dependent Input Jitter	DDJ			0.1	UI	
Data Input Total Jitter	TJ			0.28	UI	
<b>Receiver</b>						
Single Ended Output Voltage Tolerance		0.3		4	V	
Rx Output Diff Voltage	Vo		600	800	mV	
Rx Output Rise and Fall Voltage	Tr/Tf			35	ps	1
Total Jitter	TJ			0.7	UI	
Deterministic Jitter	DJ			0.42	UI	

Note 1: 20~80%

Address	Name	Description
128	Identifier (1 Byte)	Identifier Type of serial transceiver
129	Ext. Identifier (1 Byte)	Extended identifier of serial transceiver
130	Connector (1 Byte)	Code for connector type
131-138	Transceiver (8 Bytes)	Code for electronic compatibility or optical compatibility
139	Encoding (1 Byte)	Code for serial encoding algorithm
140	BR, nominal (1 Byte)	Nominal bit rate, units of 100 Mbits/s
141	Extended RateSelect Compliance (1 Byte)	Tags for Extended RateSelect compliance
142	Length SMF (1 Byte)	Link length supported for SM fiber in km
143	Length E-50 $\mu\text{m}$ (1 Byte)	Link length supported for EBW 50/125 $\mu\text{m}$ fiber, units of 2 m
144	Length 50 $\mu\text{m}$ (1 Byte)	Link length supported for 50/125 $\mu\text{m}$ fiber, units of 1 m
145	Length 62.5 $\mu\text{m}$ (1 Byte)	Link length supported for 62.5/125 $\mu\text{m}$ fiber, units of 1 m
146	Length copper (1 Byte)	Link length supported for copper, units of 1 m
147	Device Tech (1 Byte)	Device technology
148-163	Vendor name (16 Bytes)	QSFP vendor name (ASCII)
164	Extended Transceiver (1 Byte)	Extended Transceiver Codes for InfiniBand <sup>†</sup>
165-167	Vendor OUI (3 Bytes)	QSFP vendor IEEE vendor company ID
168-183	Vendor PN (16 Bytes)	Part number provided by QSFP vendor (ASCII)
184-185	Vendor rev (2 Bytes)	Revision level for part number provided by vendor (ASCII)
186-187	Wavelength (2 Bytes)	Nominal laser wavelength (Wavelength = value / 20 in nm)
188-189	Wavelength Tolerance (2 Bytes)	Guaranteed range of laser wavelength (+/- value) from Nominal wavelength (Wavelength Tol. = value / 200 in nm)
190	Max Case Temp (1 Byte)	Maximum Case Temperature in Degrees C
191	CC_BASE (1 Byte)	Check code for Base ID fields (addresses 128-190)
192-195	Options (4 Bytes)	Rate Select, TX Disable, TX Fault, LOS
196-211	Vendor SN (16 Bytes)	Serial number provided by vendor (ASCII)
212-219	Date code (8 Bytes)	Vendor's manufacturing date code
220	Diagnostic Monitoring Type (1 Byte)	Indicates which type of diagnostic monitoring is implemented
221	Enhanced Options (1 Byte)	Indicates which optional enhanced features are implemented
222	Reserved (1 Byte)	Reserved
223	CC_EXT	Check code for the Extended ID Fields (addresses 192-222)
224-255	Vendor Specific (32 Bytes)	Vendor Specific EEPROM

# TIMING FOR SOFT CONTROL AND STATUS FUNCTIONS

Parameter	Symbol	Max	Unit	Conditions
Initialization Time	t_init	2000	ms	Time from power on [1], hot plug or rising edge of Reset until the module is fully functional [2].
Reset Init Assert Time	t_reset_init	2	µs	A Reset is generated by a low level longer than the minimum reset pulse time present on the ResetL pin.
Serial Bus Hardware Ready Time	t_serial	2000	ms	Time from power on [1] until module responds to data transmission over the 2-wire serial bus.
Monitor Data Ready Time	t_data	2000	ms	Time from power on [1] to data not ready, bit 0 of Byte 2, deasserted and IntL asserted.
Reset Assert Time	t_reset	2000	ms	Time from rising edge on the ResetL pin until the module is fully functional [2].
LPMODE Assert Time	ton_LPMODE	100	µs	Time from assertion of LPMODE (Vin:LPMODE=Vih) until module power consumption enters lower Power Level.
IntL Assert Time	ton_IntL	200	ms	Time from occurrence of condition triggering IntL until Vout:IntL = Vol.
IntL Deassert Time	toff_IntL	500	µs	Time from clear on read [3] operation of associated flag until Vout:IntL = Voh. This includes deassert times for Rx LOS, Tx Fault and other flag bits.
Rx LOS Assert Time	ton_los	100	ms	Time from Rx LOS state to Rx LOS bit set and IntL asserted.
Flag Assert Time	ton_flag	200	ms	Time from occurrence of condition triggering flag to associated flag bit set and IntL asserted.
Mask Assert Time	ton_mask	100	ms	Time from mask bit set [4] until associated IntL assertion is inhibited.
Mask De-assert Time	toff_mask	100	ms	Time from mask bit cleared [4] until associated IntL operation resumes.
ModSelL Assert Time	ton_ModSelL	100	µs	Time from assertion of ModSelL until module responds to data transmission over the 2-wire serial bus.
ModSelL Deassert Time	toff_ModSelL	100	µs	Time from deassertion of ModSelL until the module does not respond to data transmission over the 2-wire serial bus.
Power_over-ride or Power-set Assert Time	ton_Pdown	100	ms	Time from P_Down bit set [4] until module power consumption enters lower Power Level.
Power_over-ride or Power-set De-assert Time	toff_Pdown	300	ms	Time from P_Down bit cleared [4] until the module is fully functional [3].

**Note 1:** Power on is defined as the instant when supply voltages reach and remain at or above the minimum specified value.

**Note 2:** Fully functional is defined as IntL asserted due to data not ready bit, bit 0 byte 2 de-asserted.

**Note 3:** Measured from falling clock edge after stop bit of read transaction.

**Note 4:** Measured from falling clock edge after stop bit of write transaction.

## PIN ASSIGNMENT

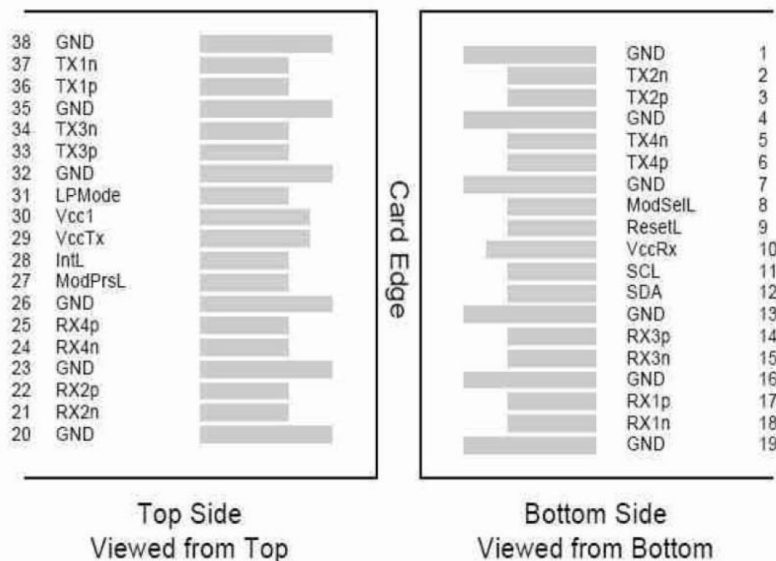

Diagram of host board connector block pin numbers and name

## PIN DESCRIPTION

Pin	Logic	Symbol	Name / Description	Note
1		GND	Ground	1
2	CML-I	Tx2n	Transmitter Inverted Data Input	
3	CML-I	Tx2p	Transmitter Non-Inverted Data Input	
4		GND	Ground	1
5	CML-I	Tx4n	Transmitter Inverted Data Input	
6	CML-I	Tx4p	Transmitter Non-Inverted Data Input	
7		GND	Ground	1
8	LVTTL-I	ModSelL	Module Select	
9	LVTTL-I	ResetL	Module Reset	
10		VccRx	+3.3 V Power Supply Receiver	2
11	LVC MOS-I/O	SCL	2-Wire Serial Interface Clock	
12	LVC MOS-I/O	SDA	2-Wire Serial Interface Data	
13		GND	Ground	
14	CML-O	Rx3p	Receiver Non-Inverted Data Output	
15	CML-O	Rx3n	Receiver Inverted Data Output	
16		GND	Ground	1
17	CML-O	Rx1p	Receiver Non-Inverted Data Output	
18	CML-O	Rx1n	Receiver Inverted Data Output	
19		GND	Ground	1
20		GND	Ground	1
21	CML-O	Rx2n	Receiver Inverted Data Output	
22	CML-O	Rx2p	Receiver Non-Inverted Data Output	
23		GND	Ground	1
24	CML-O	Rx4n	Receiver Inverted Data Output	
25	CML-O	Rx4p	Receiver Non-Inverted Data Output	
26		GND	Ground	1
27	LVTTL-O	ModPrsL	Module Present	
28	LVTTL-O	IntL	Interrupt	
29		VccTx	+3.3 V Power Supply Transmitter	2
30		Vcc1	+3.3 V Power Supply	2
31	LVTTL-I	LPMODE	Low Power Mode	
32		GND	Ground	1
33	CML-I	Tx3p	Transmitter Non-Inverted Data Input	
34	CML-I	Tx3n	Transmitter Inverted Data Input	
35		GND	Ground	1
36	CML-I	Tx1p	Transmitter Non-Inverted Data Input	
37	CML-I	Tx1n	Transmitter Inverted Data Input	
38		GND	Ground	1

**Notes:**

1. GND is the symbol for signal and supply (power) common for QSFP modules. All are common within the QSFP module and all module voltages are referenced to this potential unless otherwise noted. Connect these directly to the host board signal common ground plane. Laser output disabled on TDIS >2.0V or open, enabled on TDIS <0.8V.
2. VccRx, Vcc1 and VccTx are the receiver and transmitter power suppliers and shall be applied concurrently. Recommended host board power supply filtering is shown below. VccRx, Vcc1 and VccTx may be internally connected within the QSFP transceiver module in any combination. The connector pins are each rated for a maximum current of 500mA.

**RECOMMENDED CIRCUIT**

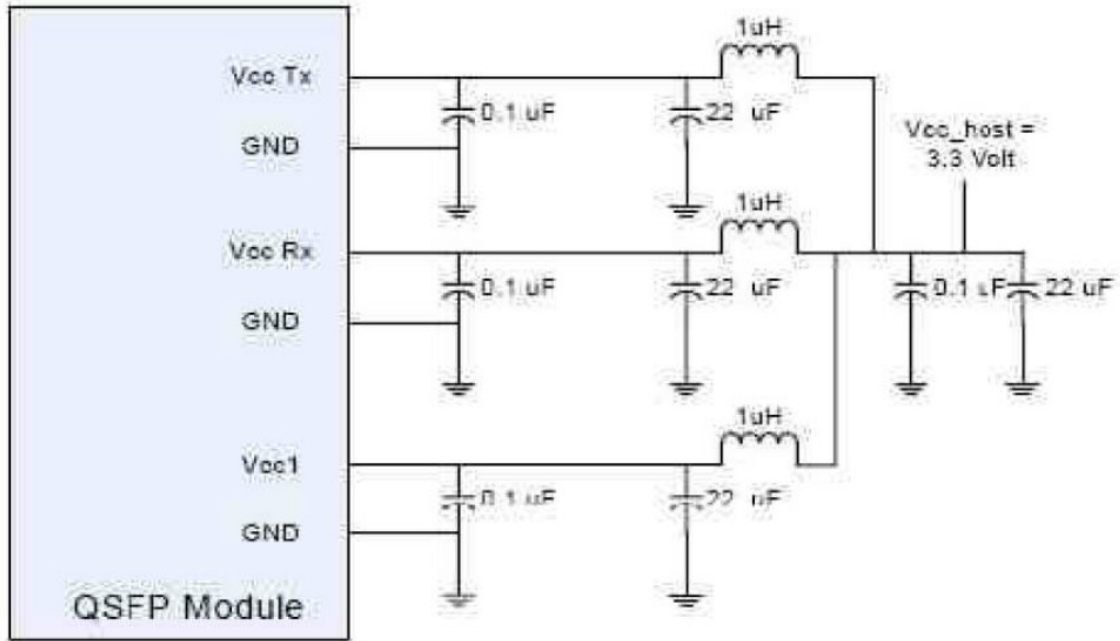

# MECHANICAL DIMENSIONS

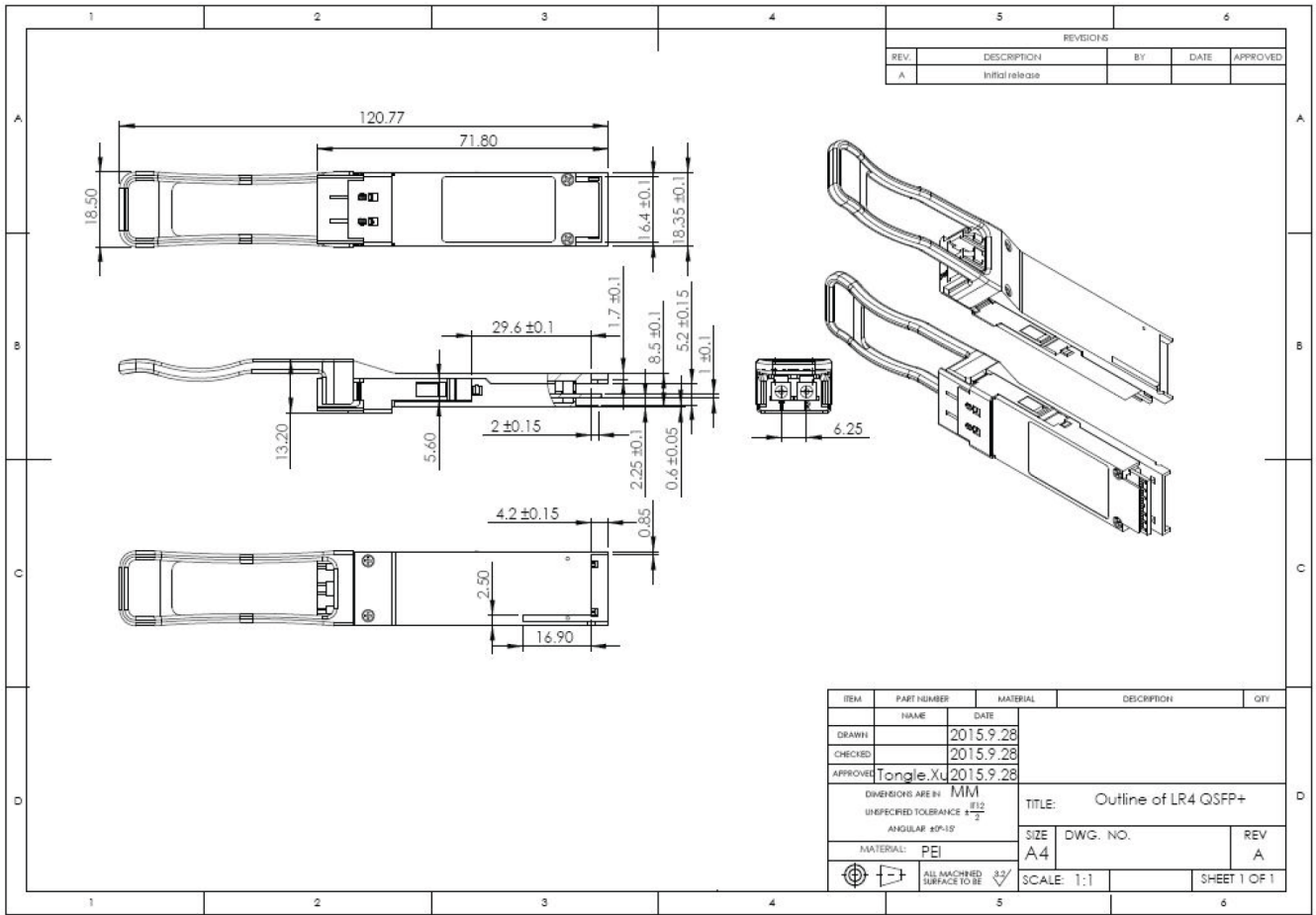

# ORDERING INFORMATION

Part Number	Product Description
-------------	---------------------

PT-40G-SR-BD-RX

RX ONLY 40GBASE-SR BIDI QSFP+