

PT-400G-SR8-85

DATASHEET



PRODUCT FEATURES

400GBASE-SR8 QSFP-DD Module

- ▶ Data rate up to 425 Gbps (8x PAM4 53 Gbps)
- ▶ Reach up to 70 m on MMF (OM3) or 100 m on MMF (OM4)
- ▶ 850 nm VCSEL laser and PIN receiver
- ▶ High speed I/O electrical interface (400GAUI-8)
- ▶ I2C interface with integrated Digital Diagnostic monitoring
- ▶ Single MPO-16 receptacle
- ▶ Single +3.3V power supply
- ▶ Power consumption <10 W
- ▶ Operating case temperature: 0 to +70°C
- ▶ Compliant with RoHS2.0

ABSOLUTE MAXIMUM RATINGS

Parameter	Symbol	Min	Max	Unit
Storage Temperature	T_s	-40	85	°C
Supply Voltage	V_{CC}	-0.5	4.0	V
Relative Humidity (non-condensing)	RH	15	85	%

RECOMMENDED OPERATING CONDITIONS

Parameter	Symbol	Min	Typical	Max	Unit	Note
Operating Case Temperature	T_{OPR}	0		70	°C	
Power Supply Voltage	V_{CC}	3.13	3.3	3.47	V	
Power Supply Current	I_{CC}			3	A	
Maximum Power Dissipation	P_D			10	W	
Lane Baud Rate	BR_{LANE}		26.5625		GBd	
Transmission Distance	TD			70	m	Over MMF OM3
Transmission Distance	TD			100	m	Over MMF OM4

OPTICAL CHARACTERISTICS

Parameter	Symbol	Min	Typical	Max	Unit	Note
Transmitter						
Data Rate, each lane		26.5625 ± 100 ppm			GBd	
Center Wavelength	λ_c	840	850	860	nm	
RMS Spectral width	$\Delta\lambda$			0.6	nm	
Average Launch Power, each lane		-6.5		4.0	dBm	
Outer Optical Modulation Amplitude (OMA _{outer}), each lane	T _{OMA}	-4.5		3	dBm	
Launch Power in OMA _{outer} minus TDECQ, each lane	T _{OMA}	-5.9			dBm	
Transmitter and Dispersion Eye Closure for PAM4 (TDECQ), each lane	TDECQ			4.5	dB	
TDECQ – 10log10 (Ceq)				4.5	dB	
Average Output Power (laser turn off)	T _{OFF}			-30	dBm	
Extinction Ratio, each lane	ER	3			dB	
RIN ₂ OMA	RIN			-128	dB/HZ	
Optical Return Loss Tolerance	ORL			12	dB	
Encircled flux at 4.5µm				30	%	
Encircled flux at 19µm		86			%	
Receiver						
Data Rate, each lane		26.5625 ± 100 ppm			GBd	
Center Wavelength	λ_c	840	850	860	nm	
Damage Threshold, each lane		5			dBm	
Average Receive Power, each lane	AOP _R	-8.4		4.0	dBm	
Receive Power (OMA _{outer}), each lane	OMA _R			3	dBm	1
Receiver Reflectance	RR			-12	dB	
Receiver Sensitivity (OMA _{outer}), each lane	S _{OMA}			max(-6.5, SECQ-7.9)	dBm	1
Stressed Receiver Sensitivity (OMA _{outer}), each lane	SRS			-3.4	dBm	2
LOS Assert	LOSA	-20			dBm	
LOS De-Assert	LOSD			-7.5	dBm	
LOS Hysteresis	LOSH	0.5		5	dB	

Notes:

1. Measured at TP3 for BER 2.4E-4 Pre-FEC.
2. Conditions of stressed receiver sensitivity test:
 Stressed eye closure for PAM4 (SECQ), lane under test = 4.5 dB;
 SECQ – 10log 10 (C eq) (max), lane under test = 4.5 dB;
 OMA of each aggressor lane = 3 dBm.

ELECTRICAL CHARACTERISTICS

Electrical Specification High Speed Signal (compliant with IEEE 802.3bs 400GAUI-8)

Parameter	Symbol	Min	Typical	Max	Unit	Note
Transmitter (Module Input, TP1)						
Signaling rate per lane			26.5625		GBd	
Differential pk-pk input voltage tolerance		900			mV	
Differential input return loss		9.5 - 0.37f for 0.01≤f<8 4.75 - 7.4log ₁₀ (f/14) for 8 ≤f<19				
Differential to common mode input return loss		22-20(f/25.78) for 0.01≤f<12.89 15 - 6log ₁₀ (f/25.78) for 12.89≤f<19				
Differential termination mismatch				10	%	
Module stressed input test		Per section 120E.3.4.1, IEEE 802.3bs				
Single-ended voltage tolerance range		-0.4		3.3	V	
DC common mode voltage		-350		2850	mV	
Receiver (Module Output, TP4)						
Signaling rate per lane			26.5625		GBd	
AC common-mode output voltage (RMS)				17.5	mV	
Differential output voltage				900	mV	
Near-end ESMW (eye symmetry mask width)			0.265		UI	
Near-end eye height, differential		70			mV	
Far-end ESMW (eye symmetry mask width)			0.2		UI	
Far-end eye height, differential		30			mV	
Far-end pre-cursor ratio		-4.5		2.5	%	
Differential output return loss		9.5 - 0.37f for 0.01≤f<8 4.75 - 7.4log ₁₀ (f/14) for 8 ≤f<19			dB	
Common to differential mode conversion return loss		22-20(f/25.78) for 0.01≤f<12.89 15 - 6log ₁₀ (f/25.78) for 12.89≤f<19			dB	
Differential termination mismatch				10	%	
Transition time, 20% to 80%		9.5			ps	
DC common mode voltage		-350		2850	mV	

Electrical Specification Low Speed Signal (compliant with QSFP-DD HW Rev 5.1)

Parameter	Symbol	Min	Max	Unit	Condition
Module output SCL and SDA	V _{OL}	0	0.4	V	
Module input SCL and SDA	V _{IL}	-0.3	V _{CC} *0.3	V	
	V _{IH}	V _{CC} *0.7	V _{CC} +0.5	V	
InitMode, ResetL and ModSelL	V _{IL}	-0.3	0.8	V	
	V _{IH}	2	V _{CC} +0.3	V	
IntL	V _{OL}	0	0.4	V	
	V _{OH}	V _{CC} -0.5	V _{CC} +0.3	V	

PIN DEFINITIONS

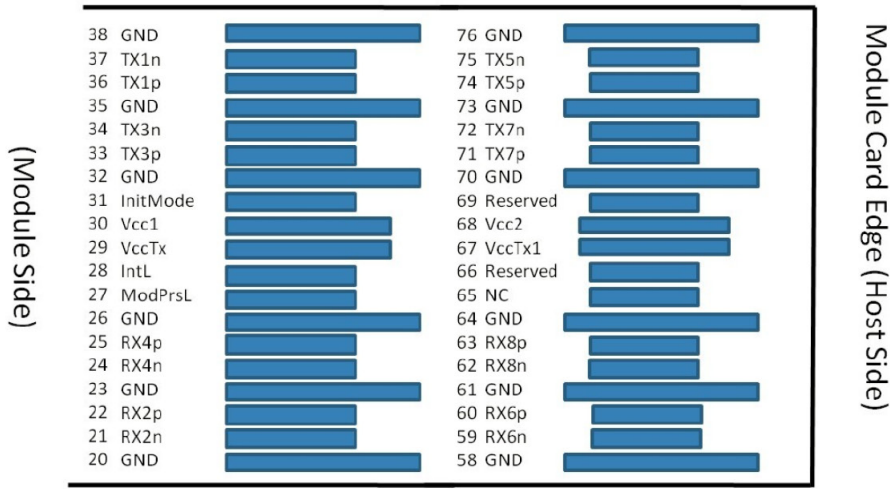

Top side viewed from top

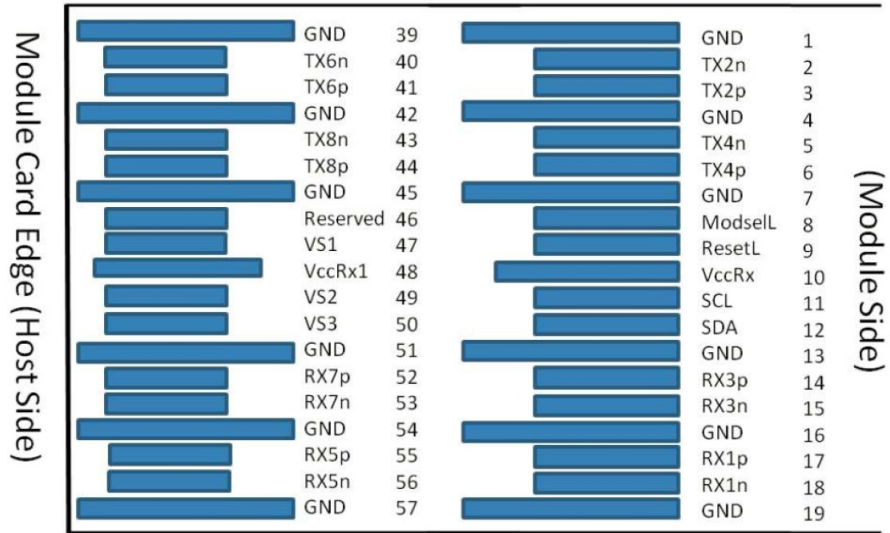

Bottom side viewed from bottom

Pin definitions of the module high speed inputs/outputs

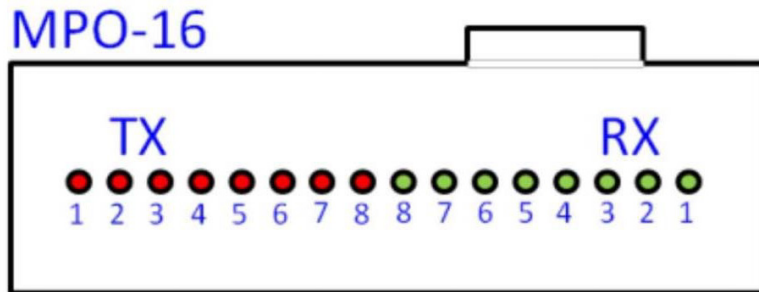

Active fiber ports in MPO-16 connector on module side

PIN DESCRIPTION

Pin	Logic	Symbol	Definition	Pin	Logic	Symbol	Definition
1		GND	Ground	39		GND	Ground
2	CML-I	Tx2n	Transmitter Inverted Data Input	40	CML-I	Tx6n	Transmitter Inverted Data Input
3	CML-I	Tx2p	Transmitter Non-Inverted Data Input	41	CML-I	Tx6p	Transmitter Non-Inverted Data Input
4		GND	Ground	42		GND	Ground
5	CML-I	Tx4n	Transmitter Inverted Data Input	43	CML-I	Tx8n	Transmitter Inverted Data Input
6	CML-I	Tx4p	Transmitter Non-Inverted Data Input	44	CML-I	Tx8p	Transmitter Non-Inverted Data Input
7		GND	Ground	45		GND	Ground
8	LVTTL-I	ModSelL	Module Select	46		Reserved	
9	LVTTL-I	ResetL	Module Reset	47		VS1	Module Vendor Specific 1
10		VccRx	+3.3 V Power Supply Receiver	48		VccRx1	3.3 V Power Supply
11	LVCMOS-I/O	SCL	2-Wire Serial Interface Clock	49		VS2	Module Vendor Specific 2
12	LVCMOS-I/O	SDA	2-Wire Serial Interface Data	50		VS3	Module Vendor Specific 3
13		GND	Ground	51		GND	Ground
14	CML-O	Rx3p	Receiver Non-Inverted Data Output	52	CML-O	Rx7p	Receiver Non-Inverted Data Output
15	CML-O	Rx3n	Receiver Inverted Data Output	53	CML-O	Rx7n	Receiver Inverted Data Output
16		GND	Ground	54		GND	Ground
17	CML-O	Rx1p	Receiver Non-Inverted Data Output	55	CML-O	Rx5p	Receiver Non-Inverted Data Output
18	CML-O	Rx1n	Receiver Inverted Data Output	56	CML-O	Rx5n	Receiver Inverted Data Output
19		GND	Ground	57		GND	Ground
20		GND	Ground	58		GND	Ground
21	CML-O	Rx2n	Receiver Inverted Data Output	59	CML-O	Rx6n	Receiver Inverted Data Output
22	CML-O	Rx2p	Receiver Non-Inverted Data Output	60	CML-O	Rx6p	Receiver Non-Inverted Data Output
23		GND	Ground	61		GND	Ground
24	CML-O	Rx4n	Receiver Inverted Data Output	62	CML-O	Rx8n	Receiver Inverted Data Output
25	CML-O	Rx4p	Receiver Non-Inverted Data Output	63	CML-O	Rx8p	Receiver Non-Inverted Data Output
26		GND	Ground	64		GND	Ground
27	LVTTL-O	ModPrsL	Module Present	65		NC	Not connected
28	LVTTL-O	IntL	Interrupt	66		Reserved	
29		VccTx	+3.3 V Power Supply Transmitter	67		VccTx1	3.3 V Power Supply
30		Vcc1	+3.3 V Power Supply	68		Vcc2	3.3 V Power Supply
31	LVTTL-I	InitMode	Initialization Mode	69		Reserved	
32		GND	Ground	70		GND	Ground
33	CML-I	Tx3p	Transmitter Non-Inverted Data Input	71	CML-I	Tx7p	Transmitter Non-Inverted Data Input
34	CML-I	Tx3n	Transmitter Inverted Data Input	72	CML-I	Tx7n	Transmitter Inverted Data Input
35		GND	Ground	73		GND	Ground
36	CML-I	Tx1p	Transmitter Non-Inverted Data Input	74	CML-I	Tx5p	Transmitter Non-Inverted Data Input
37	CML-I	Tx1n	Transmitter Inverted Data Input	75	CML-I	Tx5n	Transmitter Inverted Data Input
38		GND	Ground	76		GND	Ground

RECOMMENDED QSFP-DD HOST BOARD SCHEMATIC

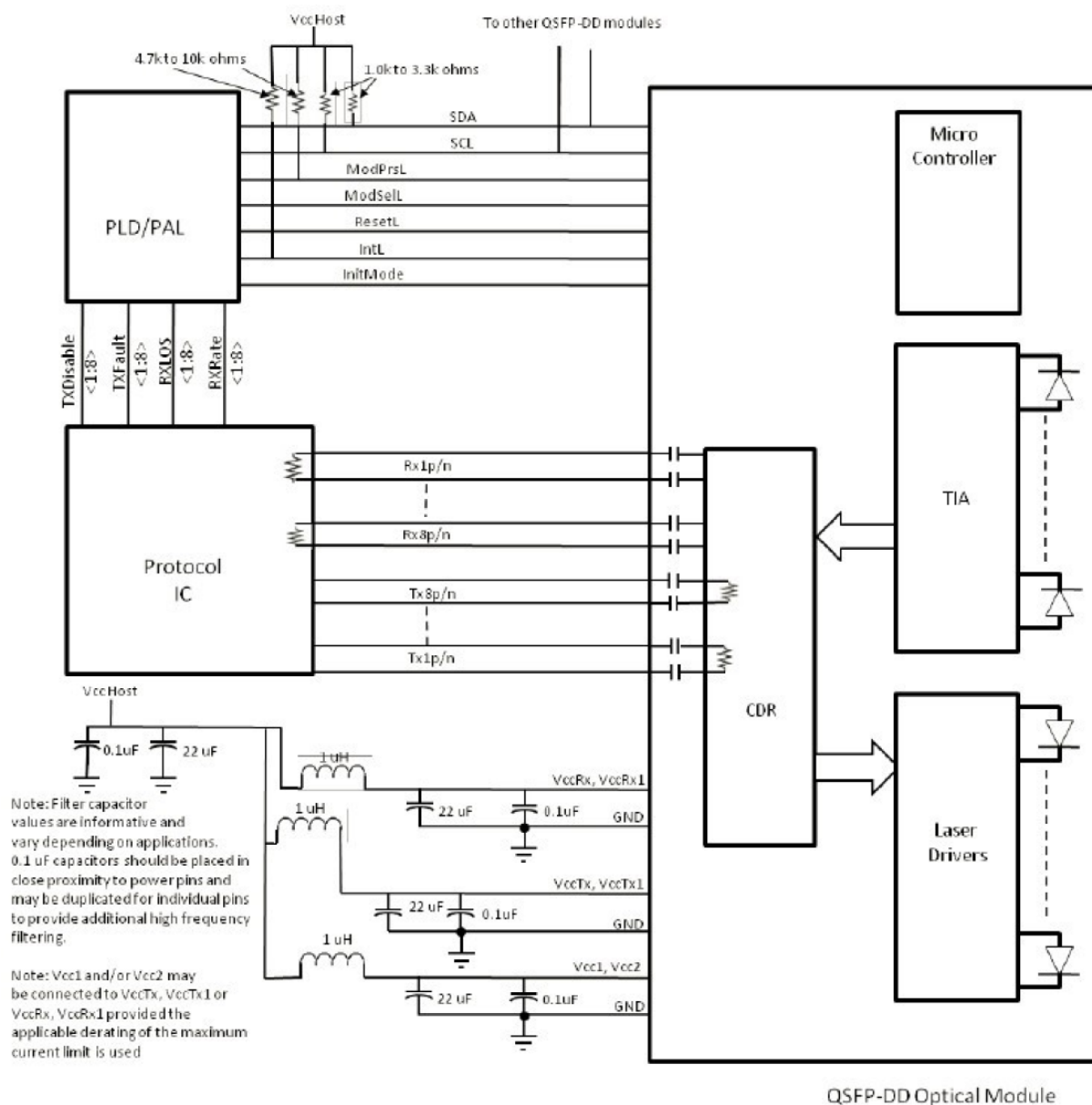

Recommended QSFP-DD Host Board Schematic

DIGITAL DIAGNOSTICS

Parameter	Accuracy	Unit	Notes
Temperature	±3	°C	Over operating temp
Voltage	±3%	V	Full operating range
Tx Bias Current (each lane)	10%	mA	Per channel
Tx Output Power (each lane)	±3	dB	Per channel
Rx Receive Power (each lane)	±3	dB	Per channel

MECHANICAL DIAGRAM

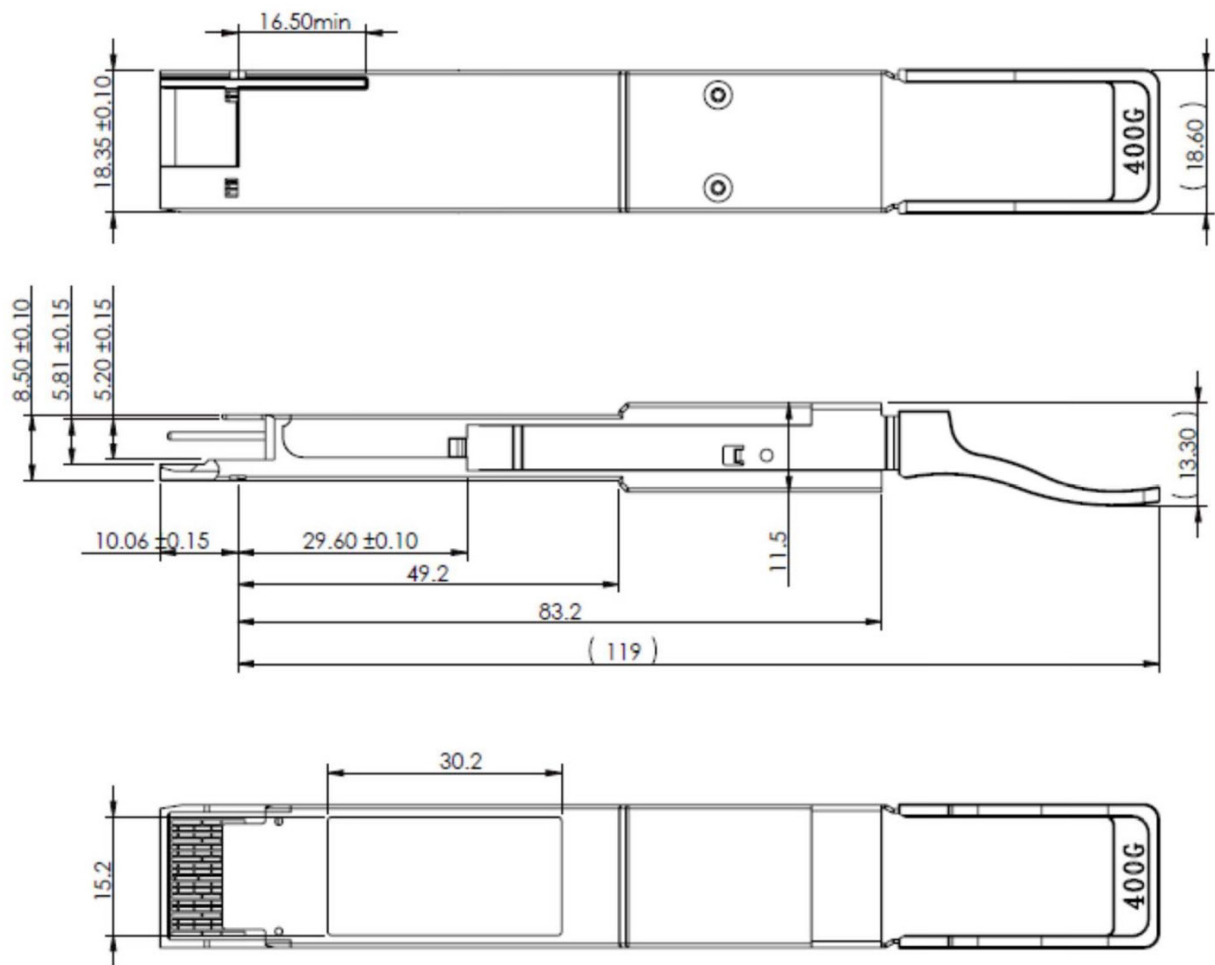

ORDERING INFORMATION

Part Number	Description	Application	Data Rate	Laser Source	Fiber Type
PT-400G-SR8-85	400G SR8 QSFP-DD	400GBASE-SR8	400G Ethernet	VCSEL	Multi-Mode Fiber