

PT-25G-LR-31

DATASHEET

PRODUCT FEATURES

25GBASE-LR Single-Mode LC 1310nm 10km SFP28 Module

- ▶ Operating data rate up to 25.78 Gbps
- ▶ Rate Adaptation
- ▶ Up to 10km transmission distance
- ▶ High-sensitivity PIN photodiode and TIA
- ▶ LC duplex connector
- ▶ Hot pluggable 20-pin connector
- ▶ Low power consumption <1.2 W
- ▶ Single +3.3V \pm 5% power supply
- ▶ Compliant with SFF-8472 & IEEE 802.3cc
- ▶ Fully RoHS Compliant
- ▶ Operating temperature range: 0°C to +70°C

Applications

- ▶ 25GBASE-LR Ethernet

GENERAL DESCRIPTION

The PT-25G-LR-31 transceiver is intended for 10km reach service 25.78Gb/s 1310nm single mode high-speed communications equipment where low-cost, extraordinary performance and reliability are essential. It consumes low power and operates based on a 3.3V DC power supply. It is compliant with SFP28 MSA, SFF-8431, and SFF-8432.

The low jitter and low bit error rate optical assembly features a DML laser transmitter and PIN/TIA receiver. It utilizes internal clock and data recovery (CDR) units on transmitter and the receiver chains for low jitter compliance. The differential AC coupled Tx and Rx data interfaces are CML compatible. The device is Class I laser safety compliant.

ABSOLUTE MAXIMUM RATINGS

Parameter	Symbol	Min	Max	Unit
Storage Temperature	$T_{Storage}$	-40	85	°C
Relative Humidity	RH	0	85	%

RECOMMENDED OPERATING CONDITIONS

Parameter	Symbol	Min	Typical	Max	Unit
Case Temperature	T_c	0		70	°C
Power Supply Voltage	V_{CC}	3.15	3.3	3.45	V
Bit Rate	BR		25.78125		Gb/s
Bit Error Ratio	BER			5×10^{-5}	
Max Supported Link Length	L			10	km

ELECTRICAL CHARACTERISTICS

Parameter	Symbol	Min	Typical	Max	Unit
Power Consumption				1.2	W
Supply Current	I_{CC}			350	mA
Transmitter					
Input Differential Impedance	R_{IN}		100		Ω
Single-ended Data Input Swing	V_{IN}	90		450	mVp-p
Transmit Disable Voltage	V_{DIS}	2		V_{CCHOST}	V
Transmit Enable Voltage	V_{EN}	V_{EE}		$V_{EE}+0.8$	V
Transmit Fault Assert Voltage	V_{FA}	2		V_{CCHOST}	V
Transmit Fault De-Assert Voltage	V_{FDA}	V_{EE}		$V_{EE}+0.4$	V
Receiver					
Single-ended Data Output Swing	V_{OD}	200		450	mVp-p
LOS Fault	V_{LOSFT}	2		V_{CCHOST}	V
LOS Normal	V_{LOSNR}	V_{EE}		$V_{EE}+0.4$	V

OPTICAL PARAMETERS

<i>Parameter</i>	<i>Symbol</i>	<i>Min</i>	<i>Typical</i>	<i>Max</i>	<i>Unit</i>
Transmitter					
Center Wavelength	λ	1290		1330	nm
Side-mode Suppression Ratio	SMSR	30			dB
Average Optical Power	P_{avg}	-7		2.0	dBm
Optical Modulation Amplitude	TxOMA	-4			dBm
Transmitter and Dispersion Penalty	TDP			1	dB
Average Launch Power of OFF Transmitter	P_{off}			-30	dBm
Extinction Ratio	ER	3.5			dB
Optical Return Loss Tolerance				11	dB
Transmitter Reflectance				-12	dB
Receiver					
Center Wavelength	λ	1260		1360	nm
Damage Threshold		3			dBm
Receive Power Overload				2	dBm
Receiver Reflectance				-26	dB
Receiver Sensitivity ¹	S			-12	dBm
LOS Assert	LOS_A	-30			dBm
LOS De-Assert	LOS_D			-17	dBm
LOS Hysteresis		0.5			dB

¹ Receiver Sensitivity measured at 25.78125 Gb/s, ER > 3.5 dBm, PRBS 2³¹-1 and BER better than or equal to 5E-5.

PIN ASSIGNMENT

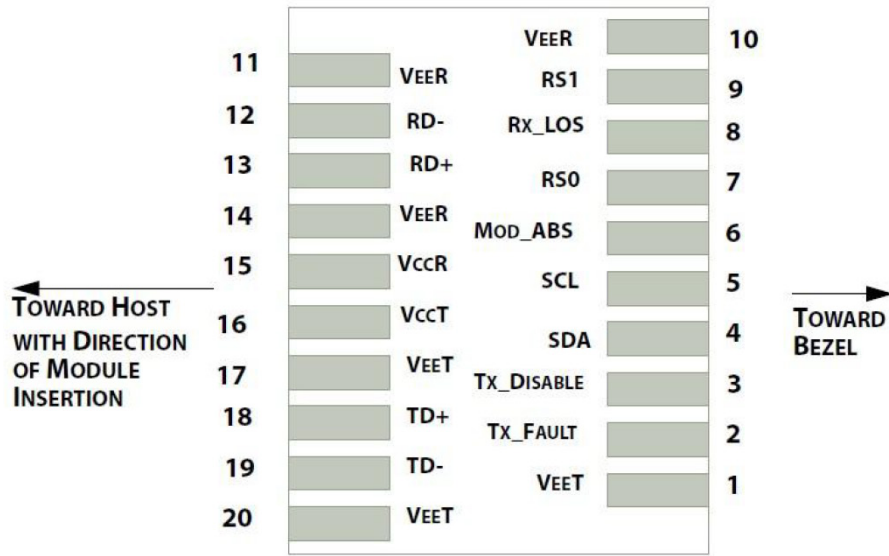
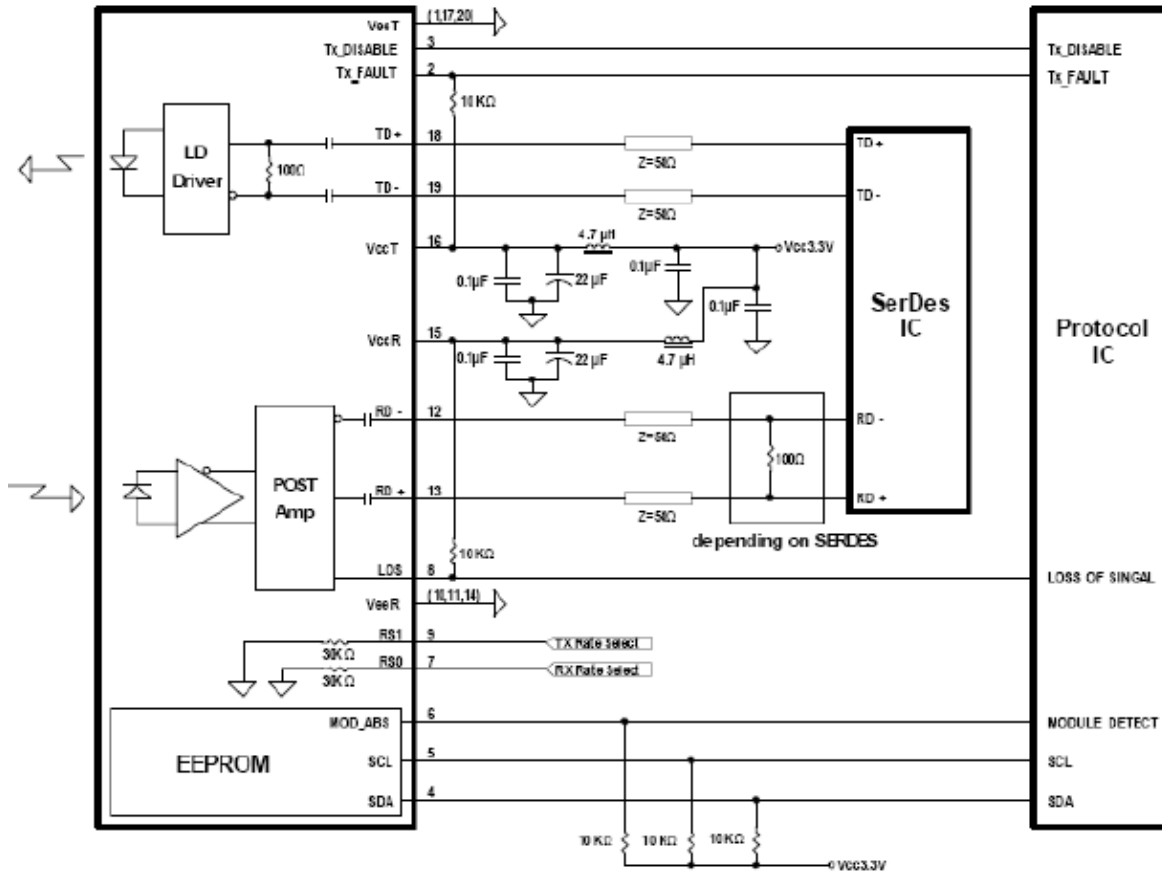

Diagram of host board connector block pin numbers and name

PIN DESCRIPTION

Pin	Symbol	Name	Description
1	VeeT	Transmitter Signal Ground	Connected to signal ground on the host board.
2	Tx Fault	Transmitter Fault Out (OC)	Module transmitter fault output.
3	Tx Disable	Transmitter Disable In (LVTTTL)	Module transmitter disable control.
4	SDA	Module Definition Identifiers	Serial ID with SFF 8472 Diagnostics Module Definition pins should be pulled up to Host Vcc with 10 kΩ resistors.
5	SCL		
6	MOD-ABS		
7	RS0	Receiver Rate Select (LVTTTL)	Rate select 0(Rx): Low=CDR Bypass; High=CDR Select
8	LOS	Loss of Signal Out (OC)	Receiver loss of signal.
9	RS1	Transmitter Rate Select (LVTTTL)	Rate select 1(Tx): Low=CDR Bypass; High=CDR Select
10	VeeR	Receiver Signal Ground	Connected to signal ground on the host board.
11	VeeR		
12	RD-	Receiver Negative DATA Out (CML)	Receiver inverted data output, internally AC coupled and terminated.
13	RD+	Receiver Positive DATA Out (CML)	Receiver non-inverted data output, internally AC coupled and terminated.
14	VeeR	Receiver Signal Ground	Connected to signal ground on the host board.
15	VccR	Receiver Power Supply	Receiver 3.3V Power Supply.
16	VccT	Transmitter Power Supply	Transmitter 3.3V Power Supply.
17	VeeT	Transmitter Signal Ground	Connected to signal ground on the host board.
18	TD+	Transmitter Positive DATA In (CML)	Transmitter non-inverted data input, internally AC coupled and terminated.
19	TD-	Transmitter Negative DATA In (CML)	Transmitter inverted data input, internally AC coupled and terminated.
20	VeeT	Transmitter Signal Ground	Connected to signal ground on the host board.

RECOMMENDED INTERFACE CIRCUIT



Typical Application Circuit

MECHANICAL DIMENSIONS

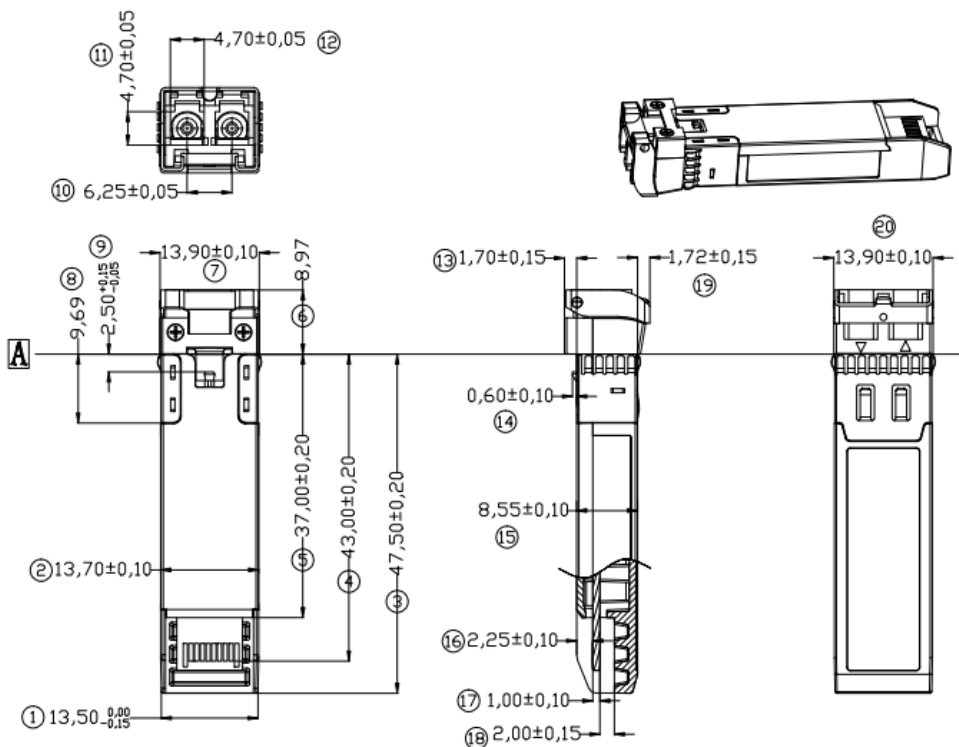

Module Mechanical Dimensions

DIGITAL DIAGNOSTICS FUNCTIONS

As defined by the SFF-8472, the SFP28 transceivers provide digital diagnostic functions via a 2-wire serial interface, which allows real-time access to the following operating parameters:

- ▶ Transceiver temperature
- ▶ Laser bias current
- ▶ Transmitted optical power
- ▶ Received optical power
- ▶ Transceiver supply voltage

It also provides a sophisticated system of alarm and warning flags, which may be used to alert end-users when particular operating parameters are outside of a factory-set normal range. The operating and diagnostics information is monitored and reported by a Digital Diagnostics Transceiver Controller (DDTC) inside the transceiver, which is accessed through the 2-wire serial interface. The memories are organized as a series of 8-bit data words that can be addressed individually or sequentially. The 2-wire serial interface provides sequential or random access to the 8-bit parameters, addressed from 0x00h to the maximum address of the memory. For more detailed information, including memory map definitions, please refer the SFF-8472 documentation.

DIGITAL DIAGNOSTIC MONITOR ACCURACY

The following characteristics are defined over recommended operating conditions:

<i>Parameter</i>	<i>Accuracy</i>	<i>Unit</i>
Internally measured transceiver temperature	+/-3	°C
Internally measured transceiver supply voltage	+/-3	%
Measured Tx bias current	+/-10	%
Measured Tx output power	+/-3	dB
Measured Rx received average optical power	+/-3	dB

ORDERING INFORMATION

<i>Part Number</i>	<i>Description</i>	<i>Application</i>	<i>Data Rate</i>	<i>Fiber Type</i>
PT-25G-LR-31	25GBASE-LR SFP28	25GBASE-LR	25G Ethernet	Single-Mode Fiber