

PT-10G-SR-85

DATASHEET

1. PRODUCT FEATURES

- ▶ 10Gb/s serial optical interface compliant to 802.3ae 10GBASE-SR
- ▶ 850nm VCSEL transmitter, PIN photo-detector
- ▶ Duplex LC connector
- ▶ Metal enclosure, for lower EMI
- ▶ Electrical interface compliant to SFF-8431 specifications for 10 Gigabit "SFP+"
- ▶ 2-wire interface for management specifications compliant with SFF 8472
- ▶ Single 3.3V power supply
- ▶ Operating temperature range:-5°C to 70°C

Parameter	Symbol	Min	Typical	Max	Unit	Notes
Center Wavelength	Vcc	-0.5		4.7	V	
Damage Threshold	TS	-40		85	°C	
Average Power at Receiver Input, each Lane	TOP	-5		70	°C	
Supply Voltage	Vcc	3.15	3.3	3.6	V	
Supply Current	Icc		185	250	mA	

TRANSMITTER

Parameter	Symbol	Min	Typical	Max	Unit	Notes
Input differential impedance	Rin		100		Ω	1
Single ended data input swing	Vin,pp	180		700	mV	
Transmit Disable Voltage	VD	Vcc-1.3		Vcc	V	
Transmit Enable Voltage	VEN	Vee		Vee+ 0.8	V	2
Transmit Disable Assert Time				10	us	

RECEIVER

Parameter	Symbol	Min	Typical	Max	Unit	Notes
Differential data output swing	Vout,pp	300		850	mV	3
Data output rise time	tr	28			ps	4
Data output fall time	tf	28			ps	4
LOS Fault	VLOS fault	Vcc-1.3		VccHOST	V	5
LOS Normal	VLOS norm	Vee		Vee+ 0.8	V	5
Power Supply Rejection	PSR	100			mVpp	6

NOTE

1. Connected directly to TX data input pins. AC coupled thereafter.
2. Or open circuit.
3. Into 100 ohms differential termination.
4. 20 – 80 % Measured with Module Compliance Test Board and OMA test pattern.
5. Loss Of Signal is LVTTTL. Logic 0 indicates normal operation; logic 1 indicates no signal detected.
6. Receiver sensitivity is compliant with power supply sinusoidal modulation of 20 Hz to 1.5 MHz up to specified value applied through the recommended power supply filtering network.

2. OPTICAL CHARACTERISTICS (TOP = -5 to 70, VCC = 3.15 to 3.60 Volts)

TRANSMITTER

Parameter	Symbol	Min	Typical	Max	Unit	Notes
Output Opt. Pwr	POUT	-5		-1	dBm	1
Optical Wavelength	λ	840	850	860	nm	
Wavelength Temperature Dependence			0.08	0.125	nm/°C	
Spectral Width (-20dB)	σ			0.45	nm	
Optical Extinction Ratio	ER	3	5.5		dB	
Sidemode Supression ratio	SSRmin	30			dB	
Optical Rise/Fall Time	tr/ tf		0.1	0	ns	
RIN	RIN			-128	dB/Hz	
Transmitter Jitter (peak to peak)			IEEE 802.3.ae requirements			

RECEIVER

Parameter	Symbol	Min	Typical	Max	Unit	Notes
Average Rx Sensitivity @ 10.325G	RSENS3			-10	dBm	2
Maximum Input Power	PMAX	0.5			dBm	
Optical Center Wavelength	λ C	840	850	860	nm	
LOS De -Assert	LOSD			-14	dBm	
LOS Assert	LOSA	-30			dBm	
LOS Hysteresis		0.5	1.0		dB	

NOTE

1. Class 1 Laser Safety per FDA/CDRH and IEC-825-1 regulations.
2. With worst-case extinction ratio. Measured with a PRBS 2³¹-1 test pattern, @10.325Gb/s, BER<10⁻¹²

3. OPTICAL CHARACTERISTICS (TOP = -5 TO 70, VCC = 3.15 TO 3.60 VOLTS)

Pin	Symbol	Name/Description	Notes
1	VEET	Transmitter Ground (Common with Receiver Ground)	1
2	TFAULT	Transmitter Fault	2
3	TDIS	Transmitter Disable. Laser output disabled on high or open.	3
4	SDA	2-wire Serial Interface Data Line	4
5	SCL	2-wire Serial Interface Clock Line	4
6	MOD_ABS	Module Absent. Grounded within the module	4
7	RS0	RS0 for Rate Select: Open or Low = Module supports 1.25 Gb/s High = Module supports 9.95 Gb/s to 10.3125 Gb/s	5
8	LOS	Loss of Signal indication. Logic 0 indicates normal operation.	6
9	RS1	No connection required	1
10	VEER	Receiver Ground (Common with Transmitter Ground)	1
11	VEER	Receiver Ground (Common with Transmitter Ground)	1
12	RD-	Receiver Inverted DATA out. AC Coupled	
13	RD+	Receiver Non-inverted DATA out. AC Coupled	
14	VEER	Receiver Ground (Common with Transmitter Ground)	1
15	VCCR	Receiver Power Supply	
16	VCCT	Transmitter Power Supply	
17	VEET	Transmitter Ground (Common with Receiver Ground)	1
18	TD+	Transmitter Non-Inverted DATA in. AC Coupled.	
19	TD-	Transmitter Inverted DATA in. AC Coupled.	
20	VEET	Transmitter Ground (Common with Receiver Ground)	1

NOTE

- 1.** Circuit ground is internally isolated from chassis ground.
- 2.** T_FAULT is an open collector/drain output, which should be pulled up with a 4.7k – 10k Ohms resistor on the host board if intended for use. Pull up voltage should be between 2.0V to Vcc + 0.3V. A high output indicates a transmitter fault caused by either the TX bias current or the TX output power exceeding the preset alarm thresholds. A low output indicates normal operation. In the low state, the output is pulled to <0.8V.
- 3.** Laser output disabled on TDIS >2.0V or open, enabled on TDIS <0.8V.
- 4.** Should be pulled up with 4.7k - 10 kohms on host board to a voltage between 2.0V and 3.6V.
MOD_ABS pulls line low to indicate module is plugged in.
- 5.** Transceiver data rate selected through the 2-wire bus in accordance with SFF-8472 Rev. 10.5. Soft RS0 is set at Bit3, Byte 110, Address A2h. Soft RS0 default state on power up is '0' LOW, and the state is reset following a power cycle. Writing '1' HIGH selects max. data rate operation. Transceiver data rate is the logic OR of the input state of the RS0 pin and soft RS0 bit. Thus, if either the RS0 pin OR the soft RS0 bit is HIGH then the selected data rate will be 9.95 and 10.3 Gb/s.
- 6.** Loss Of Signal is LVTTL. Should be pulled up with 4.7kΩ – 10kΩ on host board to a voltage between 2.0V and 3.6V. Logic 0 indicates normal operation; logic 1 indicates loss of signal.

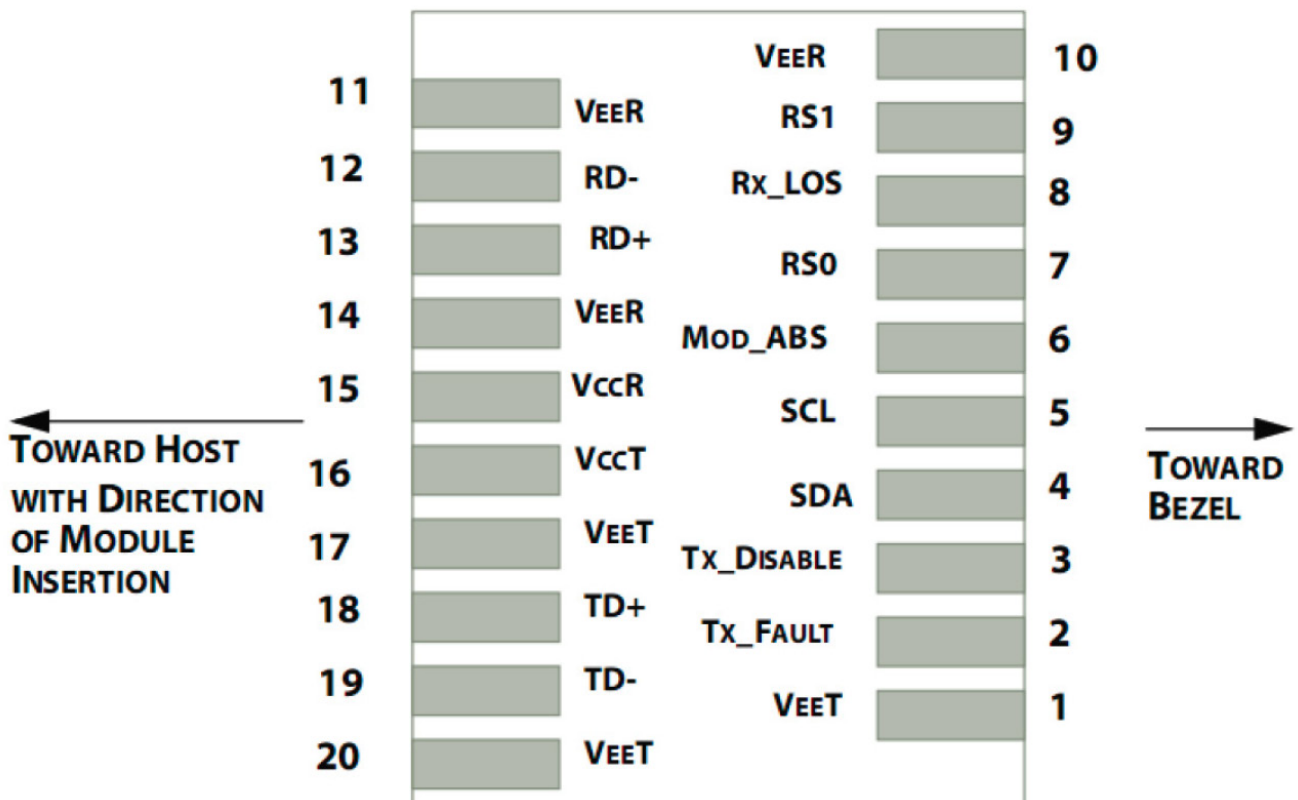

4. DIGITAL DIAGNOSTIC FUNCTIONS

Profitap PT-10G-SR-85 transceivers support the 2-wire serial communication protocol as defined in the SFP MSA1.

The standard SFP serial ID provides access to identification information that describes the transceiver’s capabilities, standard interfaces, manufacturer, and other information.

Additionally, Profitap SFP+ transceivers provide a unique enhanced digital diagnostic monitoring interface, which allows real-time access to device operating parameters such as transceiver temperature, laser bias current, transmitted optical power, received optical power and transceiver supply voltage. It also defines a sophisticated system of alarm and warning flags, which alerts end-users when particular operating parameters are outside of a factory set normal range.

The SFP MSA defines a 256-byte memory map in EEPROM that is accessible over a 2-wire serial interface at the 8 bit address 1010000X (A0h). The digital diagnostic monitoring interface makes use of the 8 bit address 1010001X (A2h), so the originally defined serial ID memory map remains unchanged.

The operating and diagnostics information is monitored and reported by a Digital Diagnostics Transceiver Controller (DDTC) inside the transceiver, which is accessed through a 2-wire serial interface. When the serial protocol is activated, the serial clock signal (SCL, Mod Def 1) is generated by the host. The positive edge clocks data into the SFP transceiver into those segments of the E2PROM that are not write-protected. The negative edge clocks data from the SFP transceiver. The serial data signal (SDA, Mod Def 2) is bi-directional for serial data transfer. The host uses SDA in conjunction with SCL to mark the start and end of serial protocol activation. The memories are organized as a series of 8-bit data words that can be addressed individually or sequentially.

Digital diagnostics for the PT-10G-SR-85 are Internally calibrated by default.

5. HOST - TRANSCEIVER INTERFACE BLOCK DIAGRAM

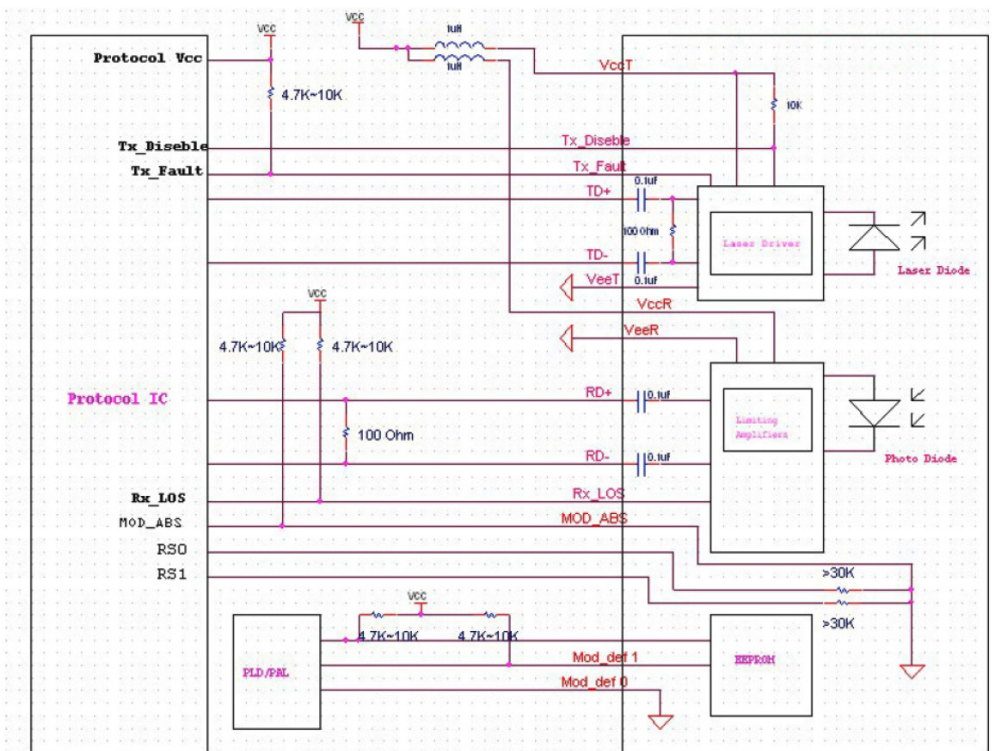

6. MECHANICAL

Comply to SFF-8432 rev. 1.2, the improved Pluggable form factor specification.

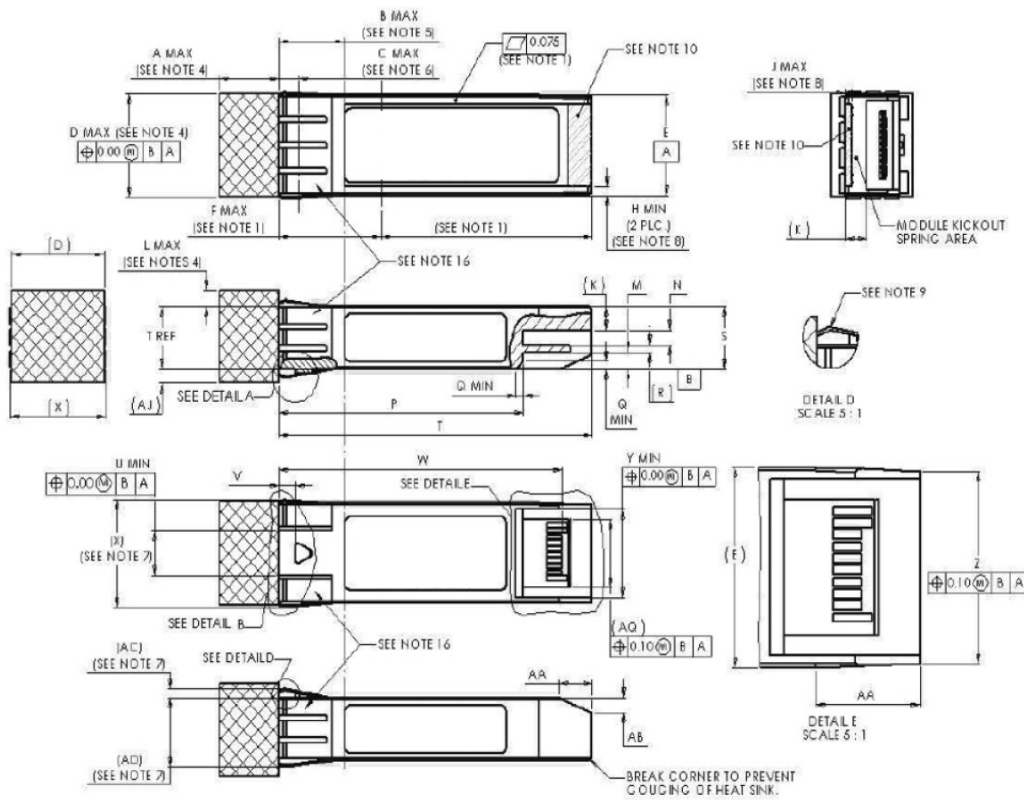

Designator	Dimension (mm)	Tolerance (mm)	Comments
A	10.00	Recommended Maximum	Module length extending outside of cage, see Note 4. Other lengths are application specific.
B	10.00	Maximum	Designated EMI ground spring area, see Note 5
C	3.00	Maximum	EMI spring/Cage Contact Point, see Note 6
D	14.00	Maximum	Module width extending outside of cage, see Note 4
E	13.55	±0.25	Module width
F	15.50	Maximum	Distance to front end of optional heat sink area, see Note 1
H	1.25	Minimum	Top slot distance from edge, see note 8
J	1.00	Maximum	Top slot depth, see note 8
K	3.25	Reference	Height of module kick-out spring area
L	2.10	Maximum	Module top height extending outside of cage see Note 4
M	2.25	±0.10	Distance from bottom of Module to printed circuit board
N	2.00	±0.25	Distance from rear shoulder to printed circuit board
P	37.10	±0.30	Distance from positive stop to bottom opening of Module and beginning of bottom rear relief